



BULK AUTOMATION

● ● ● ● ● ●

PACKAGING AND ROBOTICS SOLUTIONS

Open-Mouth Bagging

Specialists in Automated
Bagging & Palletising Systems

BAF-400M

Open Mouth Bagging

Introducing the BAF-400 Bagging Machine, designed for efficient bag filling operations. This machine has the capacity to fill up to 400 bags per hour, making it the perfect solution for a wide range of industries.

The BAF-400 bagging machine is designed with a variety of advanced features that are specifically tailored to streamline the bagging process. With a spacious 3m³ 8-tonne hopper, a durable rubber trough conveyor feed belt, an electronic load cell bag clamp, and a precise weigh indicator, this machine ensures accurate and efficient bagging.



Suitable Product Types & Sectors

Foodstuffs, Cereal & Seeds, Chemicals, Fuels, Animal Feed, Pet Food, Forestry, Minerals, Cat Litter

Product Specifications

Bags Per Hour	400 Bags P/hour
Weighing Capabilities	5-30kg
Hopper Capacity	5m ³
Power Requirements	3 Phase, 16amp
Loading Height Rear	2.9m

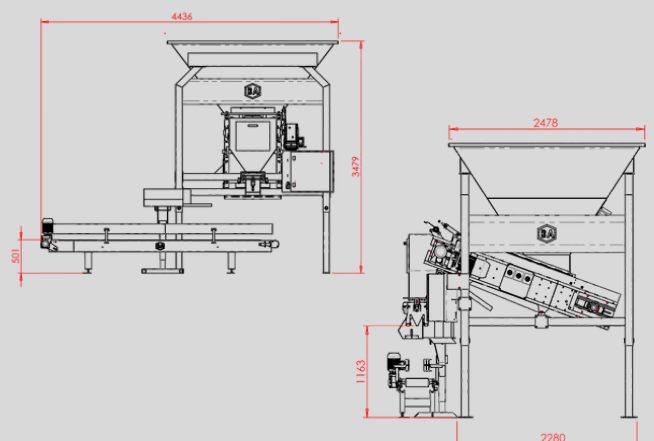

BAF-600M

Open Mouth Bagging

The BAF-600M is a semi-automatic pre-made mobile bagging system which can be customised to suit all customer requirements including robot palletising and pallet wrapping.

Ideal for customers who have available factory space the BAF-600M provides a Robust system to increase production rates. Complete with the BAF-400M, Bag Handling and ABB robotic palletiser the standard unit is a robust reliable bagging unit capable of producing 600 bags an hour.

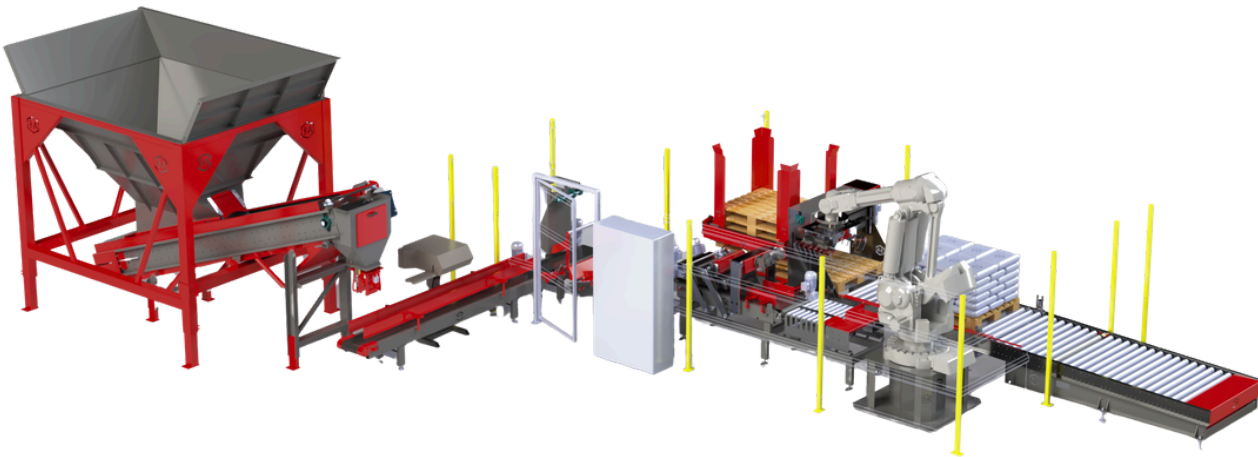

Suitable Product Types & Sectors

Foodstuffs, Cereal & Seeds, Chemicals, Fuels, Animal Feed, Pet Food, Forestry, Minerals, Cat Litter

Product Specifications

Bags Per Hour	600 Bags P/hour
Weighing Capabilities	5-30kg
Hopper Capacity	5m ³
Power Requirements	3 Phase, 20amp
Loading Height Rear	2.9m

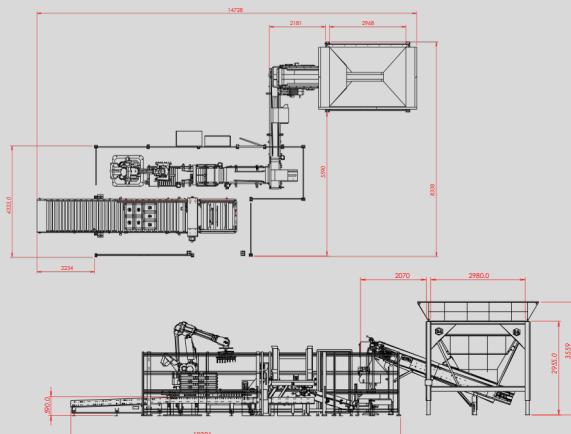

BAF-600D

Open Mouth Bagging

Introducing the BAF-600D Bagging Machine, a cutting-edge dual solution for streamlined and accurate bag filling operations of 25kg and FIBC bulk bags. With the capability to fill up to 600 small bags per hour and 60-100 FIBC bulk bags per hour, this machine is ideal for a variety of industries.

The BAF-600D is a state-of-the-art bagging machine that offers a range of advanced features to streamline the bagging process. It boasts a spacious 5m³ 15-tonne hopper, a durable rubber trough conveyor feed belt, an electronic load cell bag clamp, and a precise weigh indicator for accurate bagging.

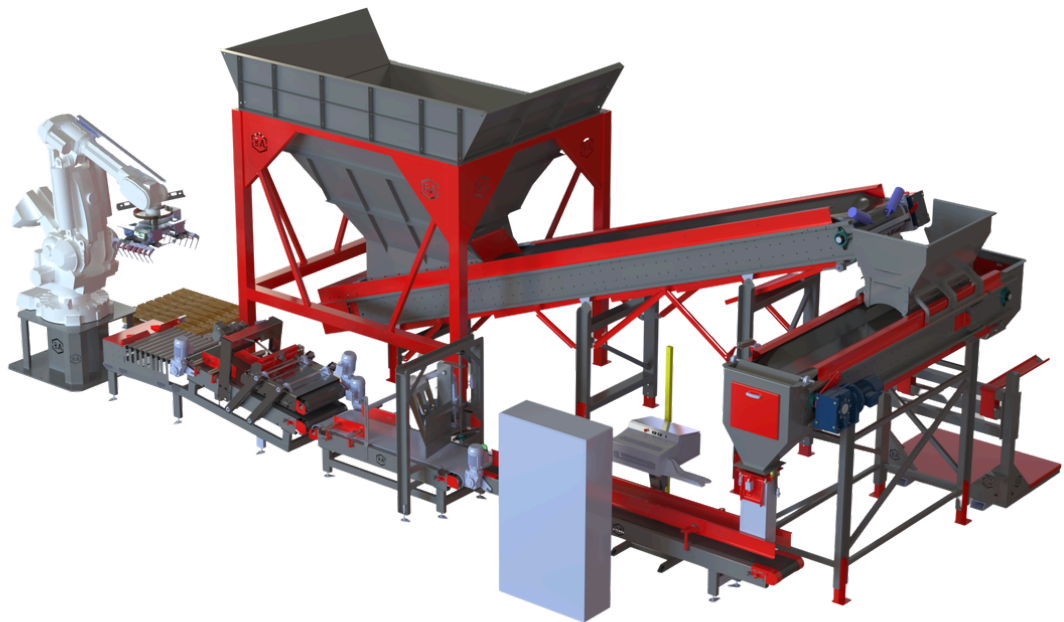

Suitable Product Types & Sectors

Foodstuffs, Cereal & Seeds, Chemicals, Fuels, Animal Feed, Pet Food, Forestry, Minerals, Cat Litter

Product Specifications

	Small Bags	Bulk Bags
Bags Per Hour	400 P/hour	100 P/hour
Weighing Capabilities	5-30kg	500-1200kg
Hopper Capacity	5m ³	
Power Requirements	3 Phase, 32amp	
Loading Height Rear	2.9m	

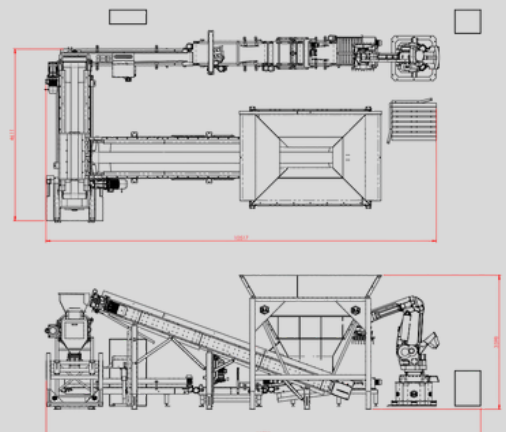

PALLETISERS

Streamline your load stacking with Bulk Automation's palletising systems. Whether you need consistency, speed, or flexibility, our mechanical and robotic palletisers are built rugged, smart, and tailored to your production needs.

Our Palletising Types

- Robotic Palletising – Flexible robot systems that adapt to different product types & stacking patterns. Perfect for medium-to-high volume, mixed or varying SKUs.
- Cartesian Palletisers – Precise, compact machines. Ideal for bags, boxes or bundles. Fits well in tight spaces while delivering strong performance.
- Push-Type / Layer Palletisers – High-throughput, excellent for consistent layering. Great where speed & load stability matter.



PALLET WRAPPING

Keep your products secure and your operation running smoothly with Bulk Automation's pallet wrapping and stretch hooding systems. Designed for strength, reliability and ease of use, our machines provide consistent load protection while reducing film waste and labour costs.

Our Wrapping & Hooding Options

- Stretch Hooding – Protective hooding stretch wrap, ideal for stability and exposure protection.
- Automatic Wrapping – Fully automated systems that wrap pallets without manual intervention.
- Semi-Automatic Wrapping – Operator assisted, for speed with control.

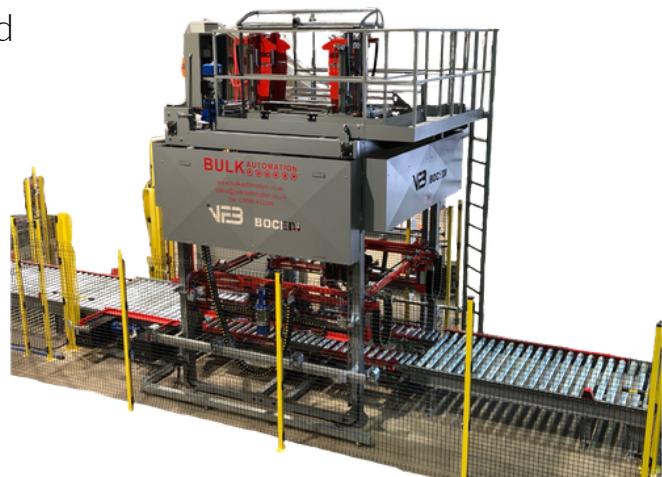

BESPOKE ROBOTIC SYSTEMS

Bulk Automation design and build robust, reliable robot palletising systems tailored to every requirement. Our palletisers boost production and consistency, with each system customised to customer needs. Using the flexible ABB robotic range, we deliver fully bespoke solutions.

Our engineers have created the “PRO STACK” program, integrated with the ABB platform, giving operators easy control of stacking patterns via the HMI.

We supply the full range of new ABB robots as well as reconditioned units. Systems range from simple floor-mounted palletisers for manual lines through to fully automatic, high-speed pallet handling solutions complete with pallet wrappers and stretch hood machines.

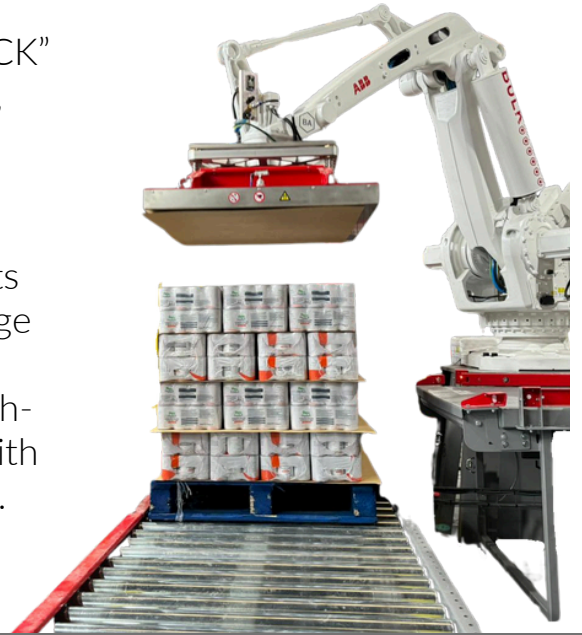

AUTOMATION ACCESSORIES

Bulk Automation supplies a full range of accessories to complete your packing line – ensuring reliability, quality control, and smooth operation.

Accessories We Supply

- Check Weighers
- Motorised Metal Detectors
- Annular Metal Detectors
- Thermal Markers
- Inkjet Printers
- Print-Apply Units
- Package Turntables
- Vacuum Chambers
- Underlay Grippers (for pallets)
- Pallet Grippers
- Bulk Bag Hydraulic Lifts



PALLET HANDLING

Streamline the movement and flow of pallets through your facility with our robust, integrated pallet handling systems. From empty pallet distribution to full-load conveyors, turntables and shuttles, we build simple but powerful automation that integrates with your existing lines.

Our Pallet Handling Options & Features

- Automatic Distributors/Pallet Dispensers – automatically feed empty pallets and underlays/PE sheets into your process.
- Rollers & Chain Conveyors – for smooth handling of full or empty pallets with minimum manual handling.
- Turntables – rotate pallet loads safely and efficiently to change orientation or direction in conveyors.
- Shuttles & Transport Platforms – mobile platforms for moving loaded or empty pallets across zones, floors or between lines



PRODUCT LOADING & TRANSPORT

Strong, efficient, and versatile systems to move your product smoothly from start to finish. We can offer:

- Load Belts - Flat belts that feed granular product into further packaging machinery. Smooth, simple, robust.
- Screw Conveyors - For powder or slow-flow products; can be horizontal, inclined or vertical; made in stainless steel (304 or 316).
- Tubular Chain Conveyor Enclosed transport for granular or powdery items over longer distances; protects delicate product; energy-efficient (up to ~50% saving over conventional conveyors).
- Bucket Elevator Lift product vertically without damage – good for fragile or delicate granules.
- Vibrating Screen Separate different sizes of granules; remove dust; clean product before packaging. Easy mesh change-over.



“ I would just like to say thank you for the excellent service you provided during the installation of, and training on, the bagging plant. I would highly recommend your company.

The staff who came to install the system and train our team were very professional. Thank you again, and we hope to do more business with you in the future. ”

Holcim Group

BULK **AUTOMATION**

PACKAGING AND ROBOTICS SOLUTIONS



BULK AUTOMATION
Llanidloes, Powys
01686 413 399
sales@bulkautomation.co.uk
www.bulkautomation.co.uk

