



BULK AUTOMATION

● ● ● ● ● ●

PACKAGING AND ROBOTICS SOLUTIONS

Open-Mouth Bagging

Specialists in Automated
Bagging & Palletising Systems

BAF-400M

Open Mouth Bagging

Introducing the BAF-400 Bagging Machine, designed for efficient bag filling operations. This machine has the capacity to fill up to 400 bags per hour, making it the perfect solution for a wide range of industries.

The BAF-400 bagging machine is designed with a variety of advanced features that are specifically tailored to streamline the bagging process. With a spacious 3m³ 8-tonne hopper, a durable rubber trough conveyor feed belt, an electronic load cell bag clamp, and a precise weigh indicator, this machine ensures accurate and efficient bagging.

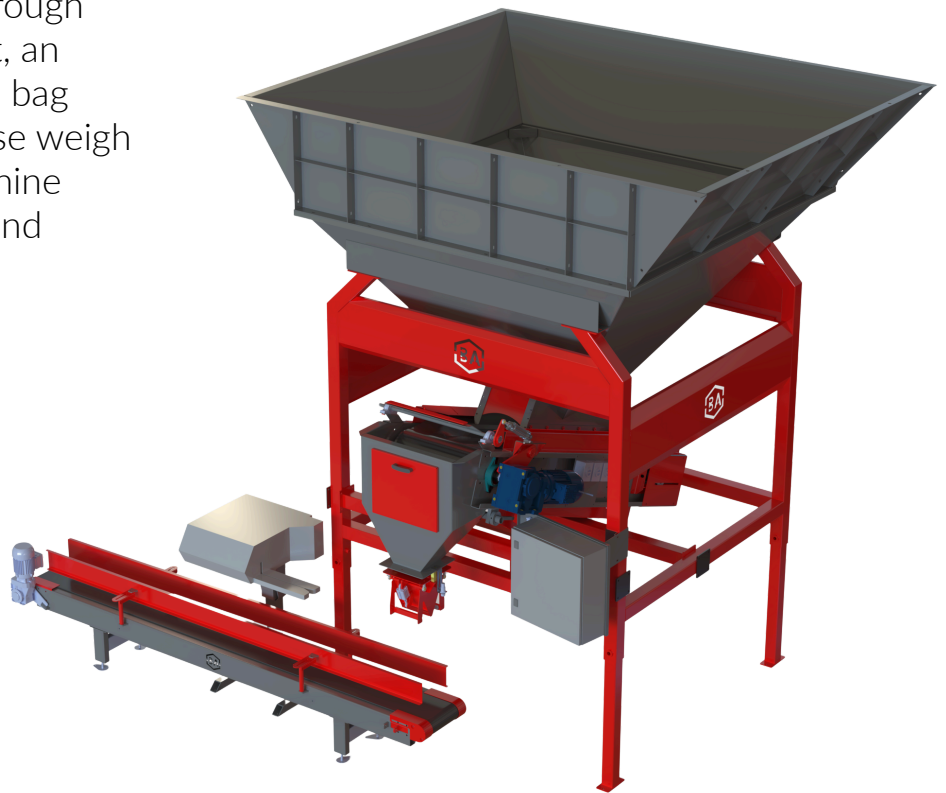

Suitable Product Types & Sectors

Foodstuffs, Cereal & Seeds, Chemicals, Fuels, Animal Feed, Pet Food, Forestry, Minerals, Cat Litter

Product Specifications

Bags Per Hour	400 Bags P/hour
Weighing Capabilities	5-30kg
Hopper Capacity	5m ³
Power Requirements	3 Phase, 16amp
Loading Height Rear	2.9m

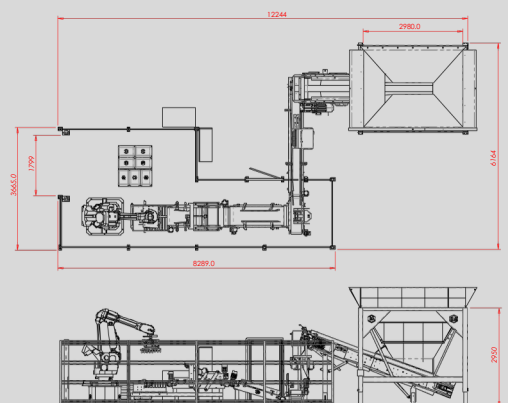

BAF-600M

Open Mouth Bagging

The BAF-600M is a semi-automatic pre-made mobile bagging system which can be customized to suit all customer requirements including robot palletising and pallet wrapping.

Ideal for customers who have available factory space the BAF-600M provides a Robust system to increase production rates. Complete with the BAF-400M, Bag Handling and ABB robotic palletiser the standard unit is a robust reliable bagging unit capable of producing 600 bags an hour.

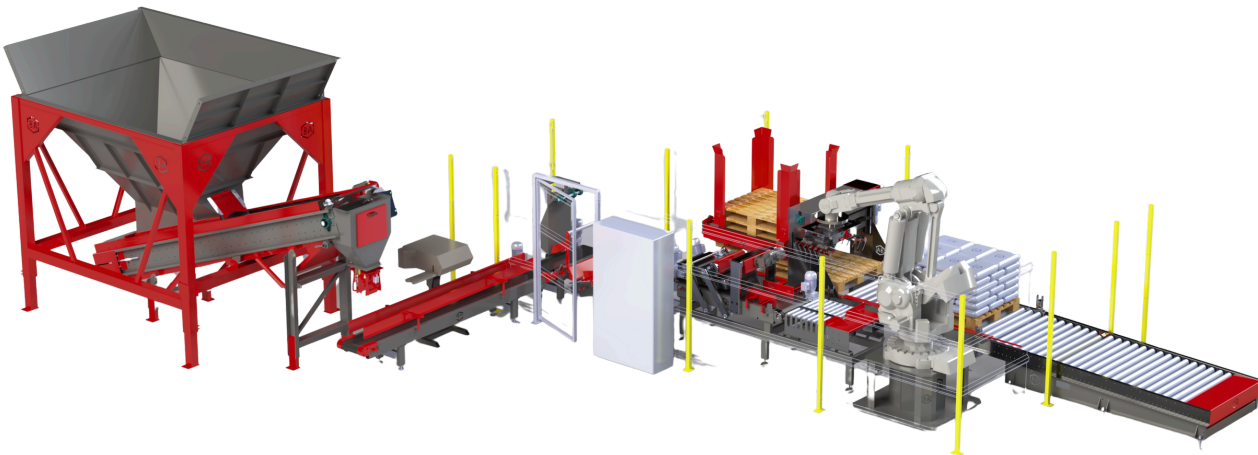

Suitable Product Types & Sectors

Foodstuffs, Cereal & Seeds, Chemicals, Fuels, Animal Feed, Pet Food, Forestry, Minerals, Cat Litter

Product Specifications

Bags Per Hour	600 Bags P/hour
Weighing Capabilities	5-30kg
Hopper Capacity	5m ³
Power Requirements	3 Phase, 20amp
Loading Height Rear	2.9m

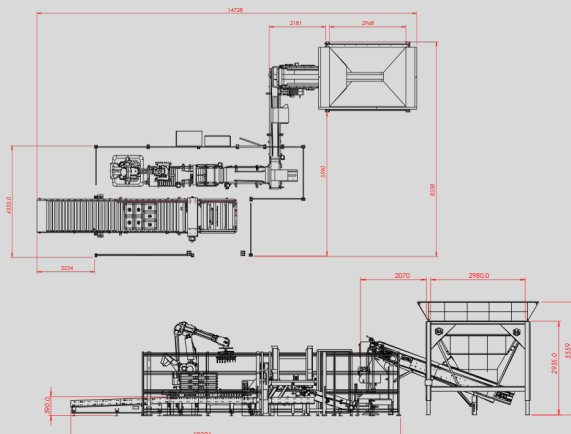

BAF-600D

Open Mouth Bagging

Introducing the BAF-600D Bagging Machine, a cutting-edge dual solution for streamlined and accurate bag filling operations of 25kg and FIBC bulk bags. With the capability to fill up to 600 small bags per hour and 60-100 FIBC bulk bags per hour, this machine is ideal for a variety of industries.

The BAF-600D is a state-of-the-art bagging machine that offers a range of advanced features to streamline the bagging process. It boasts a spacious 5m³ 15-tonne hopper, a durable rubber trough conveyor feed belt, an electronic load cell bag clamp, and a precise weigh indicator for accurate bagging..

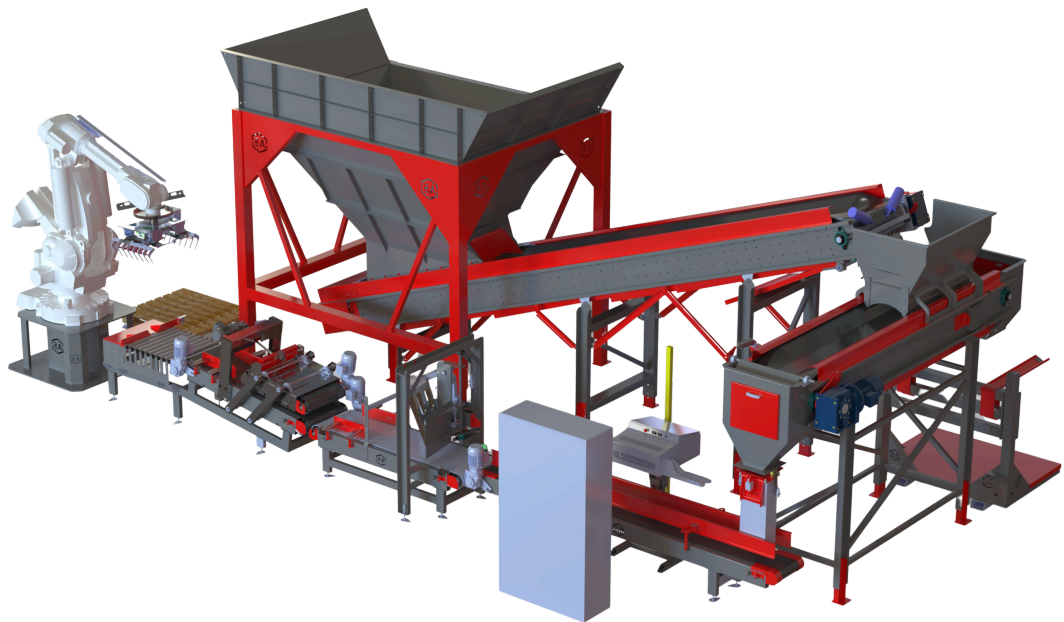

Suitable Product Types & Sectors

Foodstuffs, Cereal & Seeds, Chemicals, Fuels, Animal Feed, Pet Food, Forestry, Minerals, Cat Litter

Product Specifications

	Small Bags	Bulk Bags
Bags Per Hour	400 P/hour	100 P/hour
Weighing Capabilities	5-30kg	500-1200kg
Hopper Capacity	5m ³	
Power Requirements	3 Phase, 32amp	
Loading Height Rear	2.9m	

