



BULK AUTOMATION

● ● ● ● ● ●

PACKAGING AND ROBOTICS SOLUTIONS

Mobile Packaging Systems

Specialists in Automated
Bagging & Palletising Systems

BAC-600M

Mobile Packaging System

Our mobile bagging range also includes a fully contained manual, semi-automated, complete with an integrated robotic palletising system. Designed for maximum flexibility, the BAC-600M solution is ideal for customers with limited site space, those avoiding costly fixed installations, or businesses looking for a scalable, long-term bagging solution.

Capable of achieving throughputs of up to 700 × 25 kg bags per hour, depending on product and operator input, this high-performance system delivers consistent, reliable output while reducing labour requirements and operational costs. Housed within a robust shipping container, the bagging line offers ease of setup, minimal site preparation, and all-weather operation.

The containerised bagging system is perfectly suited for a wide range of materials, including aggregates, fertiliser, polymers, grit, salt, wood pellets, animal feed, compost, peat, soil, and more, making it a versatile and future-proof investment for growing operations.

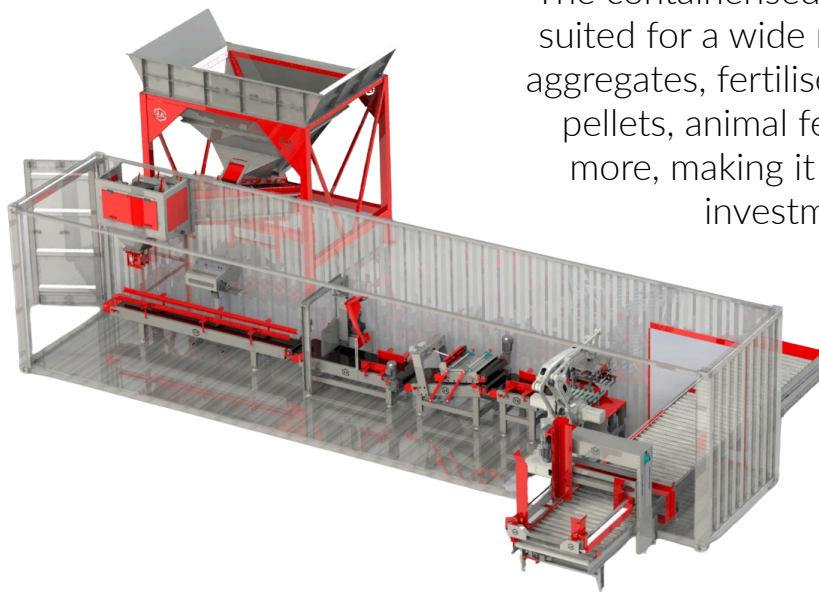

Suitable Product Types & Sectors

Cereal & Seeds, Chemicals, Fuels, Animal Feed, Pet Food, Forestry, Minerals, Cat Litter

Product Specifications

Bags Per Hour	720 Bags P/hour
Weighing Capabilities	10-25kg
Hopper Capacity	5m ³
Power Requirements	3 Phase, 63amp
Loading Height Rear	2.9m

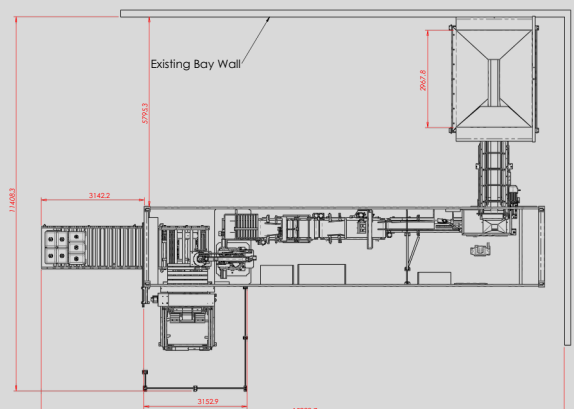

BAC-1000A

Mobile Packaging System

The BAC-1000A is the Pinicle of fully automatic mobile bagging systems, contained within two shipping containers. This cutting-edge modular system can be tailored to meet the specific requirements of each customer, with the option for robot palletizing and pallet wrapping.

Perfect for customers with limited factory space, the BAC-1000A offers a complete self-contained mobile factory solution to boost production rates.

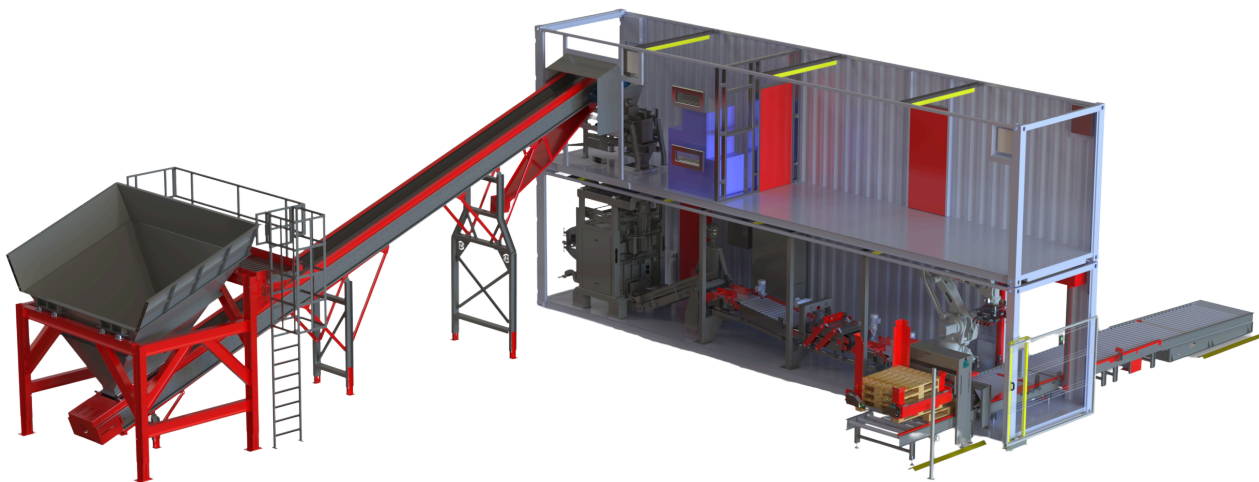

Featuring the MF54, a compact heavy-duty FFS machine, this system is specially crafted for bagging aggregates in 10kg and 25kg quantities. By using pre-printed rolls of film, the FFS system from MF Techno efficiently forms, fills, and seals bags with precision, resulting in branded products ready for sale.

Suitable Product Types & Sectors

Cereal & Seeds, Chemicals, Fuels, Animal Feed, Pet Food, Forestry, Minerals, Cat Litter

Product Specifications

Bags Per Hour	1000 Bags P/hour
Weighing Capabilities	10-25kg
Hopper Capacity	8m3
Power Requirements	3 Phase, 120amp
Loading Height Rear	2.9m

