

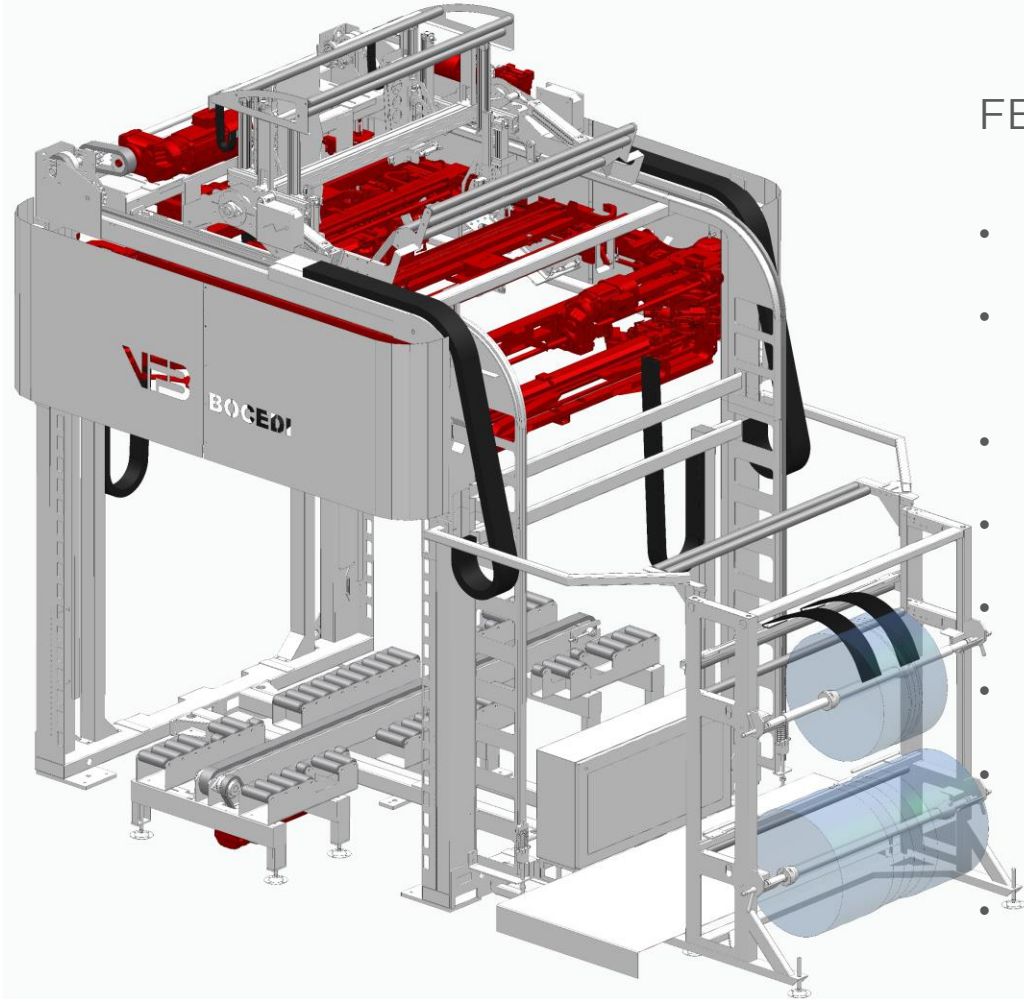

NEW STRETCH HOODER **FB3000**

VFB[®]
BOCEDI
PALLET PACKAGING SYSTEMS

THE NEW STRETCH HOODER FB3000 HAS BEEN DESIGNED TO OFFER A **FLEXIBLE** PACKAGING MACHINE CAPABLE OF WORKING WITH A LARGE VARIETY OF LOAD SHAPES AND SIZES. THE FB3000 ALSO FEATURES A **PATENTED** SYSTEM THAT ALLOWS TO DO ALL THE MAINTENANCE AT OPERATOR LEVEL.



FB3000 KEY FEATURES :

- Cartesian film stretch allows many load sizes on each film reel
- Optimized film opening system capable of processing all film types (super thin or thick , printed)
- 80 loads/h
- Compact in height , easy to fit in low ceilings
- All the maintenance at operator level
- Film reel change can be done with load presence in the machine
- All pneumatic moving parts. Selected and consolidated components , with low maintenance requirements
- Patented system

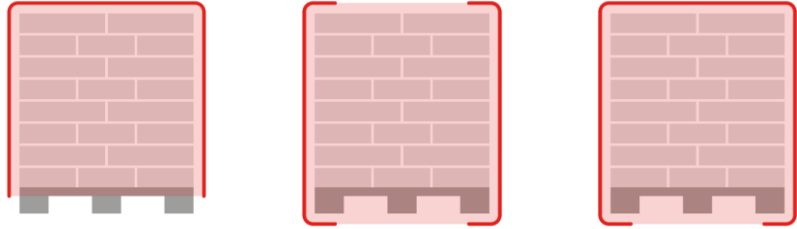

FULL HOOD : STANDARD | OPEN TOP | UNDER PALLET

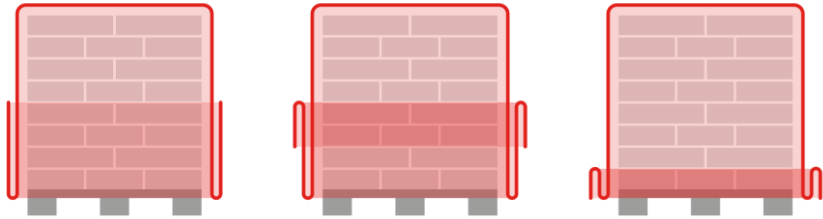

OVERLAYERS : MANY POSSIBLE CONFIGURATIONS

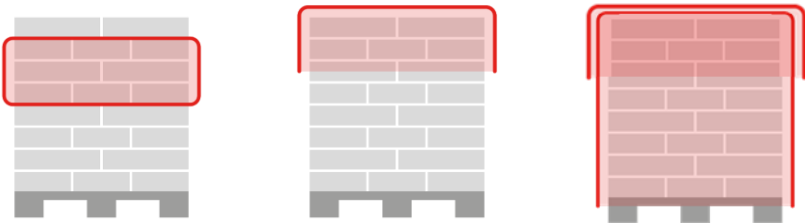

PARTIAL HOOD : BANDS | HALF HOOD | DOUBLE HOOD



NO PALLET : PALLET-LESS | SLIP SHEET

REDUCES PACKAGING PLASTIC CONSUMPTION

ONE SINGLE PLASTIC LAYER TO COVER THE COMPLETE LOAD, WITH TAILORED LENGTH ON EACH LOAD



DOWNGAUGE

THE FILM SIZE OR THICKNESS



CARBON NEUTRAL

DOES NOT USE ANY HEAT SOURCE, AND DOES NOT RELEASE ANY GAS EMISSION (GHG)



RECYCLED POLYMERS (RP)

STRETCH HOOD FILM IS 100% RECYCLABLE AND CAN ALSO BE PRODUCED WITH A % OF RECYCLED POLYMERS



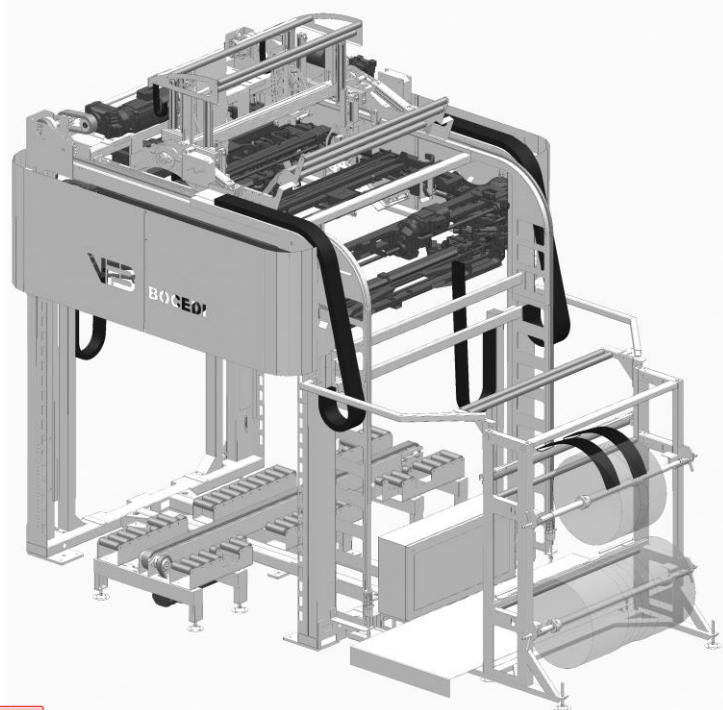

SMALL : MAX PALLET SIZE 950x800 | MAX SPEED 80/Hr

STD : MAX PALLET SIZE 1350x 1150 | MAX SPEED 70P/Hr

XL : MAX PALLET SIZE 1400x1800 | MAX SPEED 60/Hr

XXL : MAX PALLET SIZE 1400x2600 | MAX SPEED 45/Hr

 MIN. PALLET SIZE 600X600

 SIMPLE MACHINE WITH MECHANICAL / PNEUMATIC COMPONENTS _ LOW MAINTENANCE

 CONFIGURABLE WITH 2 DIFFERENT FILM TYPES/SIZES

 SUITABLE FOR ANY TYPE OF CERTIFICATION (ON REQUEST)

 AUTOMATIC HEIGHT LOAD READING, TAILORED OPTIMIZED HOOD ON EACH LOAD

FB 3000 TYPICAL LAYOUT

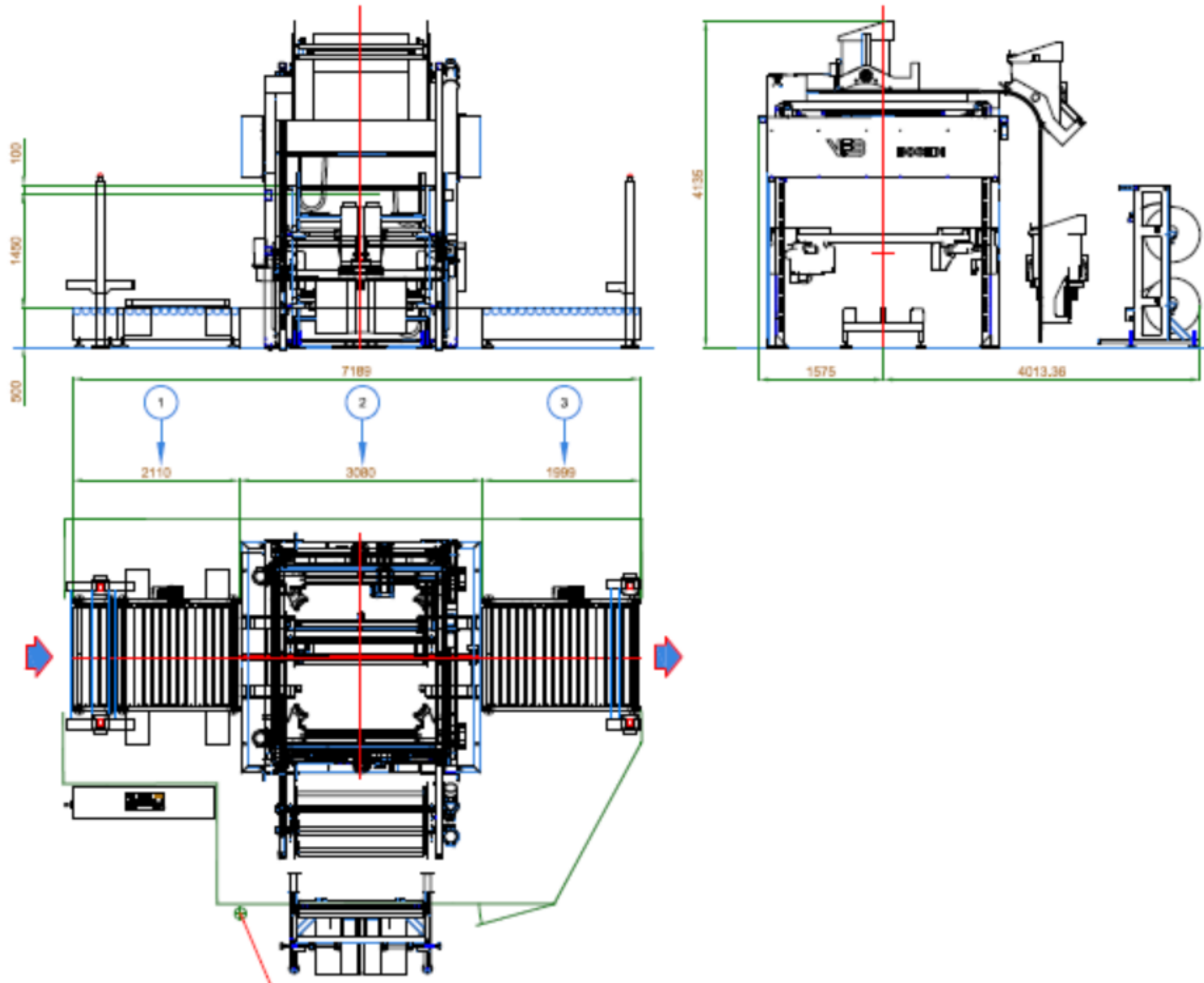

OPERATING SPEED

80 loads/hour (depending on pallet size)

PATENT n.

102019000024781

LOAD SIZE minimum

600x600 mm

LOAD WEIGHT Max

2500 Kg

FILM THICKNESS

20-200 microns

OPERATING PRESSURE

6 bar

NUMBER OF REELS max

2

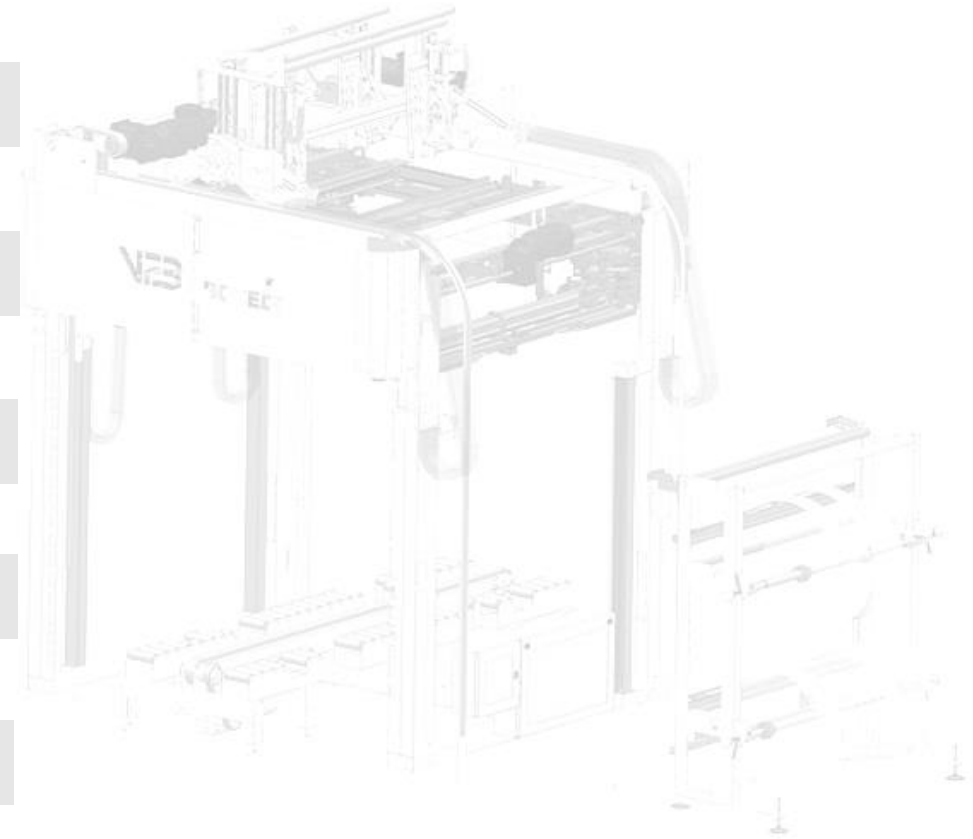

INFO → INFO@BOCEDISRL.COM



OFFICINA BOCEDI S.r.l.

Via R.Guttuso 2/A ,42019

Scandiano Reggio Emilia (ITALY)

Tel. +39 0522 767025 - info@bocedisrl.com

www.bocedisrl.com